

Model No.DHP482 CORDLESS HAMMER DRIVER DRILL

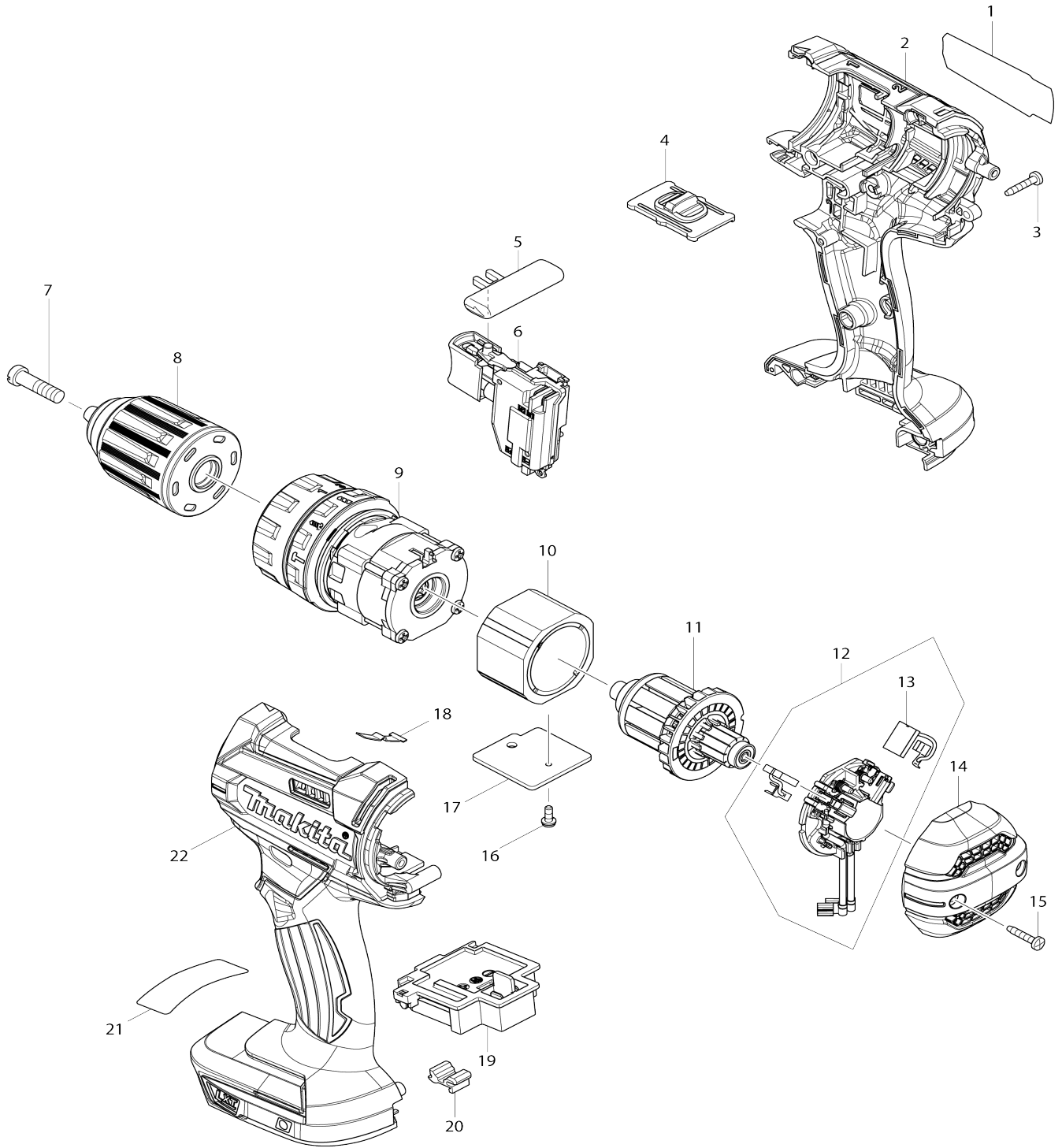

Model No.DHP482 CORDLESS HAMMER DRIVER DRILL

Item No.	Parts No.	Description	Interchangability	Q'ty	New/Old	Note1	Note2
001	851E32-8	DHP482 NAME PLATE		1	*		
001-1	857L25-5	DHP482 NAME PLATE	S	1			
002	183B65-0	HOUSING SET		1			
C10	263005-3	RUBBER PIN 6		2			
002		INC. 22					
002	183G75-7	HOUSING SET		1			
003	266429-2	TAPPING SCREW 3X16		9	*		
003-1	266130-9	TAPPING SCREW BIND PT 3X16	O	9			
004	123442-2	SPEED CHANGE LEVER ASSEMBLY		1			
C10	233438-6	COMPRESSION SPRING 4		2			
005	419041-9	F/R CHANGE LEVER		1			
006	632F27-4	SWITCH UNIT		1			
C10	620444-4	LED CIRCUIT		1			
C20	688172-7	LINE FILTER		1	*		
007	251468-5	- FLAT HEAD SCREW M6X22		1			
008	766027-7	KEYLESS DRILL CHUCK 13		1	*		
008-1	763256-3	KEYLESS DRILL CHUCK 13	O	1	*		
008-2	763262-8	KEYLESS DRILL CHUCK 13	<	1			
009	123443-0	GEAR ASSEMBLY		1			
010	632F32-1	YOKE UNIT		1	*		
010-1	632J70-7	YOKE UNIT	<	1			
011	619380-9	ARMATURE		1	*		
011-1	619583-5	ARMATURE	>	1			
012	632F21-6	BRUSH HOLDER COMPLETE		1			
C10	688172-7	LINE FILTER		1	*		
012		INC. 13					
013	194427-5	CARBON BRUSH SET CB-440		1	*		
013-1	195021-6	CARBON BRUSH SET CB-440	O	1			
014	456099-7	REAR COVER		1			
014	457927-9	REAR COVER		1			
015	266429-2	TAPPING SCREW 3X16		2	*		
015-1	266130-9	TAPPING SCREW BIND PT 3X16	O	2			
016	911006-2	PAN HEAD SCREW M3X8		1	*		
016-1	652066-2	+PAN HEAD SCREW M3X9 WITH W	<	1			
017	689070-8	HEAT SINK		1	*		
017-1	689262-9	HEAT SINK	O	1			
018	232182-2	LEAF SPRING		1			
019	644808-8	TERMINAL		1			
020	424476-1	CUSHION		1			
022	183B65-0	HOUSING SET		1			
C10	263005-3	RUBBER PIN 6		2			
022		INC. 2					
022	183G75-7	HOUSING SET		1			
023	857L26-3	DHP482 SERIAL NO. LABEL	S	1			
A01	251314-2	+ SCREW M4X12		1			
A02	346317-0	HOOK		1			

A02	346449-3	HOOK		1		
A03	784637-8	+ - BIT 2-45		1		
A04	821550-0	CONNECTOR PLASTIC CASE (TYP E2)		1		
C10	453974-8	LATCH		4		
A04	196657-4	ALUMINUM CASE SET		1		
A05	450128-8	BATTERY COVER		1		
A05	837916-4	INNER TRAY		1		
A06	***DC18RC	DC18RC FAST CHARGER		1		
A06	807S65-5	DHP482ZJ INDICATION LABEL		1	*	
A06	***DC18SD	DC18SD BATTERY CHARGER		1	*	
A06-1	816F62-2	DHP482ZJ INDICATION LABEL	O	1		
A06-1	***DC18SD	DC18SD BATTERY CHARGER	O	1		
A07	197265-4	BATTERY BL1840B SET		2	*	
A07	808J14-1	DHP482ZJ PLASTIC CASE LABEL		2	*	
A07	197280-8	BATTERY BL1850B SET		2	*	
A07	196448-3	BATTERY BL1815N SET		2	*	
A07-1	197265-4	BATTERY BL1840B SET	O	2		
A07-1	816F63-0	DHP482ZJ PLASTIC CASE LABEL	X	2		
A07-1	197280-8	BATTERY BL1850B SET	O	2		
A07-1	196235-0	BATTERY BL1815N SET	O	2		
A07-1	197600-6	BATTERY BL1830B SET		1		
A07-2	197600-6	BATTERY BL1830B SET		3		
A08	837916-4	INNER TRAY		1		
A08	D-50865	116PC.BIT SET FOR ALU CASE		1		
A08-1	8060B9-2	DHP482F3JB PLASTIC CASE LABEL		2		
A09	808J15-9	DHP482RMJ INDICATION LABEL		1	*	
A09	808V87-6	DHP482RTJ INDICATION LABEL		1	*	
A09	8059G9-8	DHP482JX13 INDICATION LABEL		1		
A09	8060B8-4	DHP482F3JB INDICATION LABEL		1		
A09-1	816F64-8	DHP482RMJ INDICATION LABEL	O	1		
A09-1	816F72-9	DHP482RTJ INDICATION LABEL	O	1		
A09-1	8018P6-9	DHP482RF1J INDICATION LABEL		1		
A09-1	8018P4-3	DHP482SF1J INDICATION LABEL		1		
A09-1	8022D4-6	DHP482FJX4 INDICATION LABEL		1		
A09-1	816F81-8	DHP482RF3J INDICATION LABEL		1		
A10	808J16-7	DHP482RMJ PLASTIC CASE LABEL		2	*	
A10	808V89-2	DHP482RTJ PLASTIC CASE LABEL		2	*	
A10	8059H0-3	DHP482JX13 PLASTIC CASE LABEL		2		
A10-1	816F65-6	DHP482RMJ PLASTIC CASE LABEL	X	2		
A10-1	816F73-7	DHP482RTJ PLASTIC CASE LABEL	X	2		
A10-1	8018P7-7	DHP482RF1J PLASTIC CASE LABEL		2		
A10-1	8018P5-1	DHP482SF1J PLASTIC CASE LABEL		2		
A10-1	8022D5-4	DHP482FJX4 PLASTIC CASE LABEL		2		
A10-1	816F82-6	DHP482RF3J PLASTIC CASE LABEL		2		
A11	E-00016	SCREW BIT 31PCS SET		1		
A11	196380-1	TOOL CHEST		1		
A11	E-08713	MAKPAC SERIES 120PCS SET		1		

A12	198253-4	COOLER BOX TYPE 4 SET		1			
A13	837916-4	INNER TRAY		1			
E02	654015-5	EARTH TERMINAL		1			
E03	654501-6	CONNECTOR P-1.25		1			

Please state Parts No. when your order.

Print Date 23/12/2024